



Practice Test

FOR GAS POSITIONS APTITUDE BATTERY

INTRODUCTION

The purpose of this Practice Test is to help you prepare for the Gas Positions Aptitude Battery placement exercise. A sample of questions based on the abilities measured in the actual placement exercise sections are included in this Practice Test. These questions are **not** the actual questions contained in the placement exercise, but rather are designed to help you practice solving questions requiring similar abilities.

Please be advised that calculators are not permitted during the actual placement exercise. It is to your advantage to answer the numerical computation questions in this Practice Test without the use of a calculator.

IMPORTANT

The information in this Practice Test is for exercise purposes only. Certain questions have been adapted from materials published by PSE&G. These materials and questions are not intended to replicate actual PSE&G work practices, diagrams, procedures, etc.

Perception, Memory and Concentration

1. The instrument reading that is different than the model reading below is:

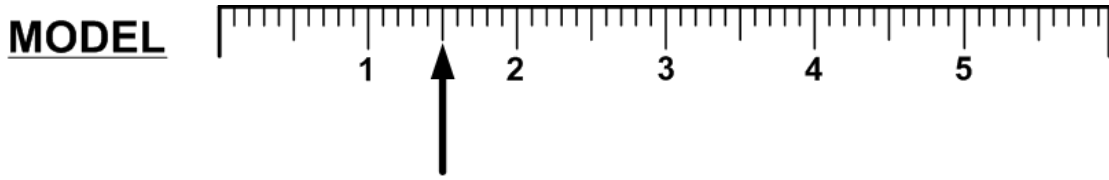

Instrument Readings

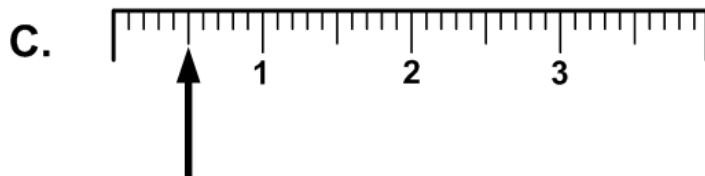
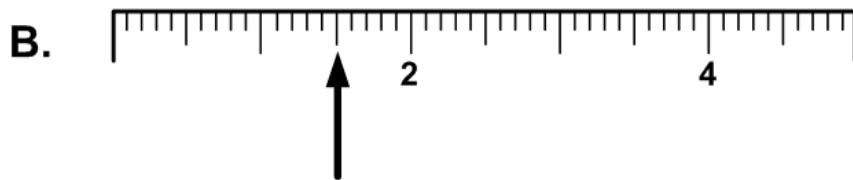
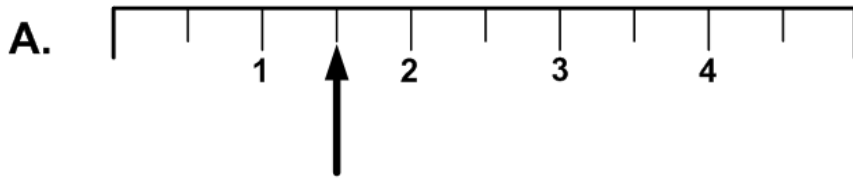

- a. Instrument Reading A
- b. Instrument Reading B
- c. Instrument Reading C
- d. None of the above.

2. The instrument reading(s) that is(are) different than the model reading below is(are):

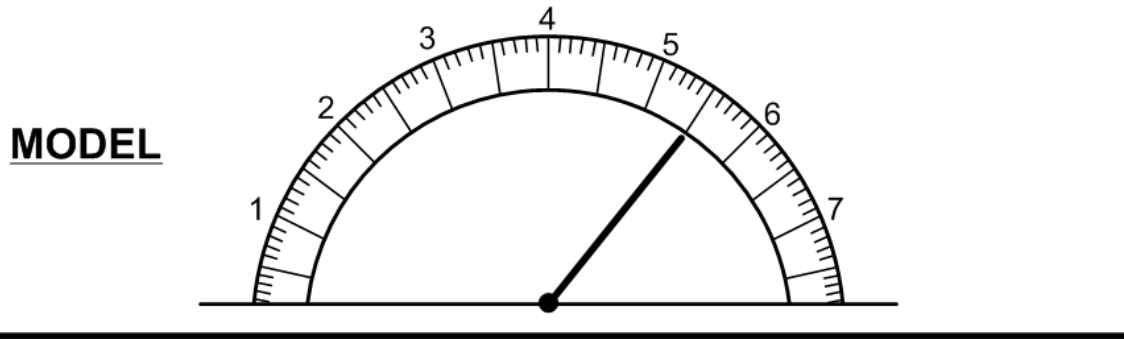

Instrument Readings

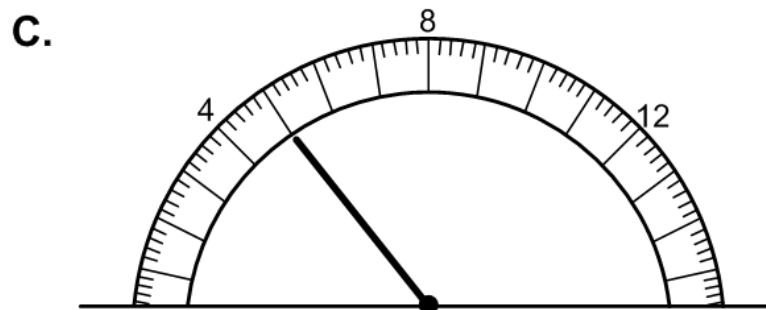
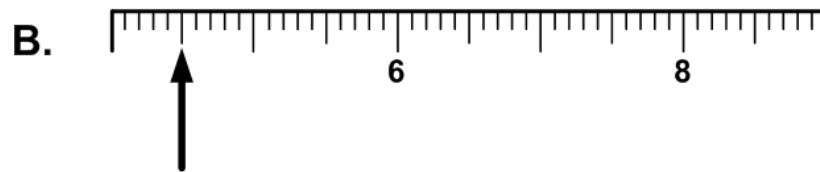
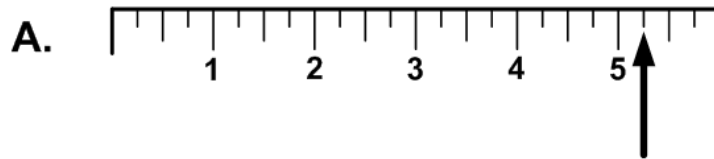

- a. Instrument Reading A
- b. Instrument Reading B
- c. Instrument Reading C
- d. All of the above.

3. The instrument reading(s) that is(are) different than the model reading below is(are):

MODEL

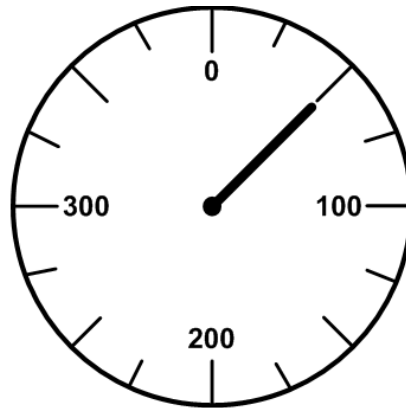

Instrument Readings

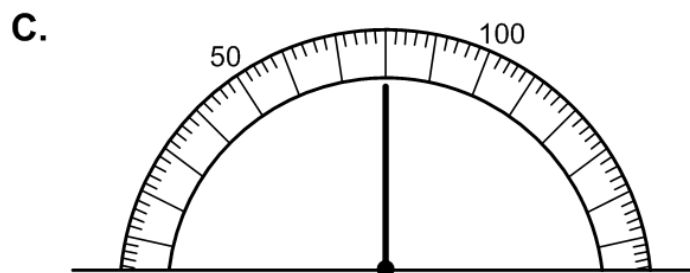
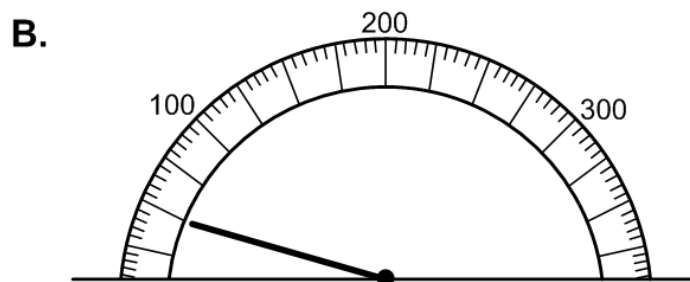
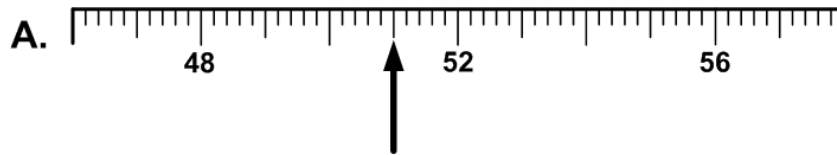

- a. Instrument Reading A
- b. Instrument Reading B
- c. Instrument Reading C
- d. Instrument Readings A and C.

Refer to Figure 1 below to answer items 4 – 6.

FIGURE 1

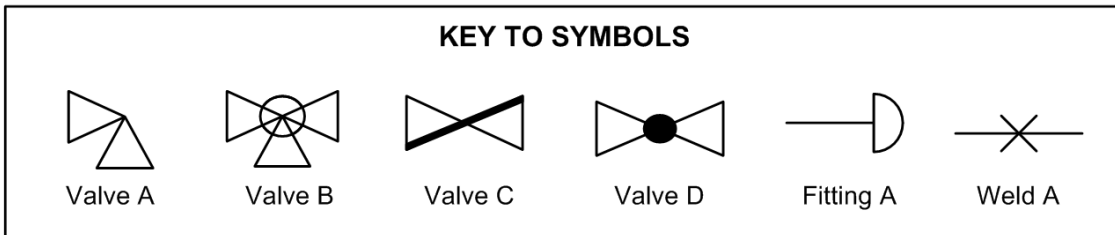
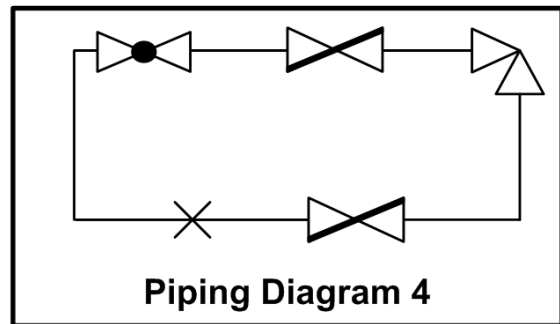
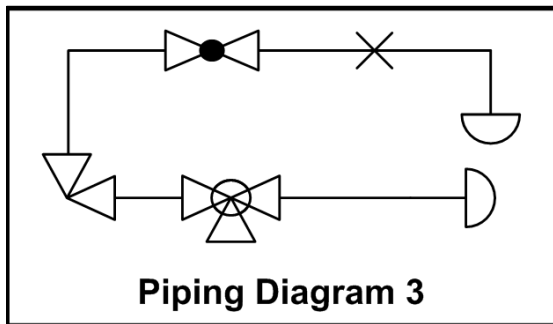
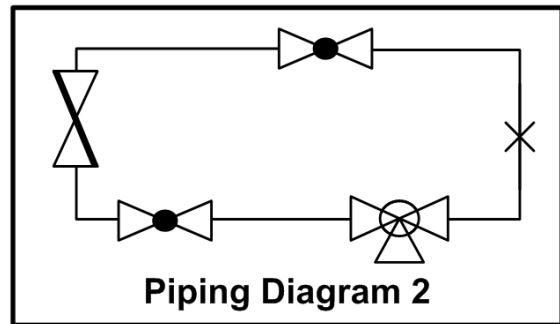
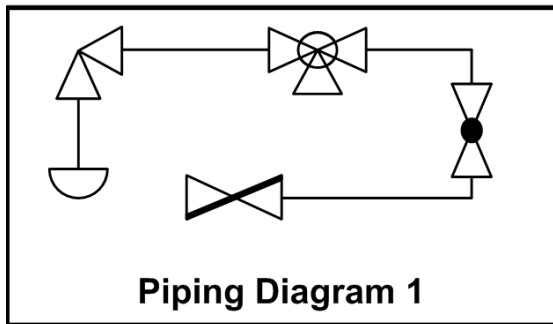

4. According to Figure 1 above, the components in the box below appear in:

- | | |
|--|---|
| <ul style="list-style-type: none">• Valve A• Valve B• Weld A | <ul style="list-style-type: none">• Fitting A• Fitting A• Valve D |
|--|---|

- a. Piping Diagram 1
- b. Piping Diagram 2
- c. Piping Diagram 3
- d. Piping Diagram 4

5. According to Figure 1 above, the components in the box below appear in:

- | | |
|--|---|
| <ul style="list-style-type: none">• Valve C• Weld A• Valve D | <ul style="list-style-type: none">• Valve B• Valve D |
|--|---|

- a. Piping Diagram 1
- b. Piping Diagram 2
- c. Piping Diagram 3
- d. Piping Diagram 4

6. According to Figure 1 above, the components in the box below appear in:

- | | |
|---|---|
| <ul style="list-style-type: none">• Valve D• Valve C• Valve A | <ul style="list-style-type: none">• Fitting A• Valve B |
|---|---|

- a. Piping Diagram 1
- b. Piping Diagram 2
- c. Piping Diagram 3
- d. Piping Diagram 4

Refer to Figure 2 below to answer items 7 – 9.

FIGURE 2

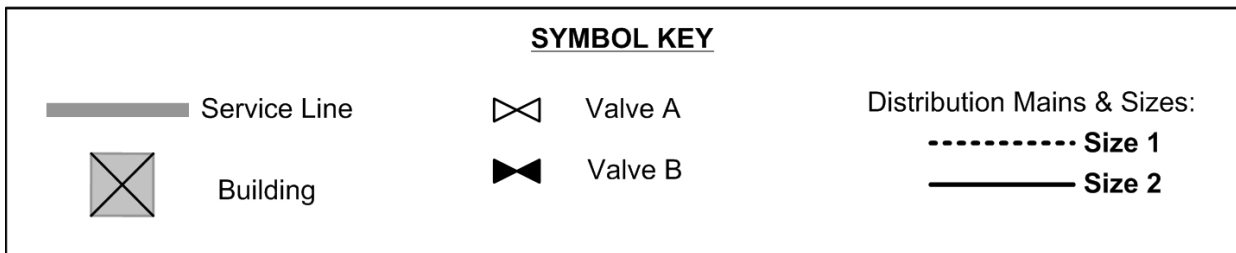
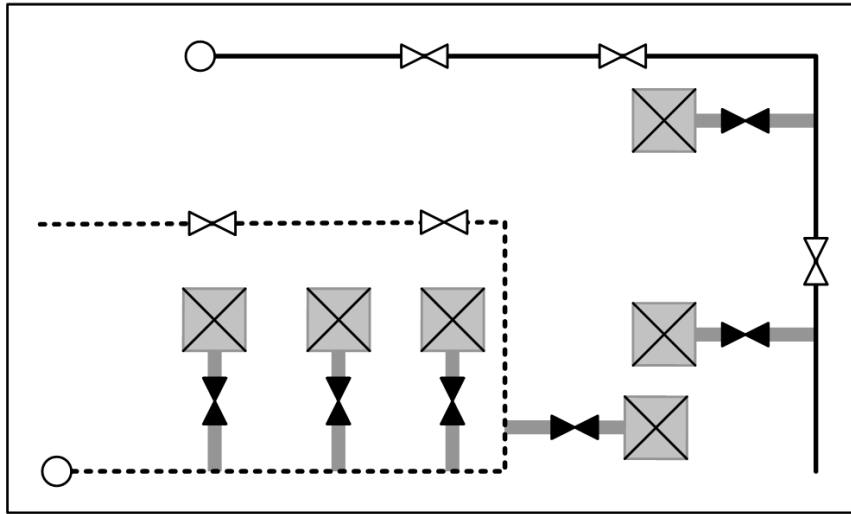

7. According to Figure 2, the total number of Valve B's attached to the Size 1 distribution main is:
- a. 3
 - b. 4
 - c. 5
 - d. 6
8. According to Figure 2, the total number of Valve A's attached to the Size 2 distribution main is:
- a. 5
 - b. 4
 - c. 2
 - d. 3
9. According to Figure 2, the total number of buildings connected to the Size 1 distribution main is:
- a. 6
 - b. 5
 - c. 4
 - d. 3

10. The diagram below that is different than the other diagrams is:

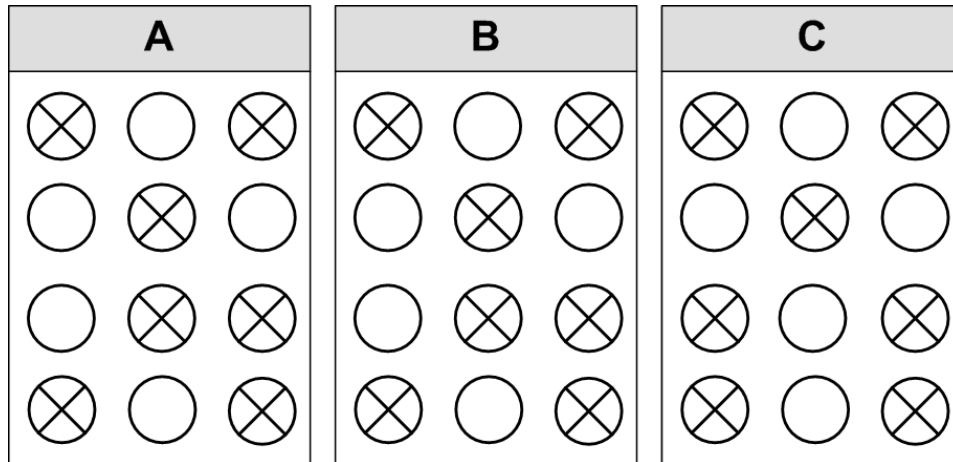

- a. A
- b. B
- c. C
- d. All of the diagrams are the same.

11. The diagram below that is different than the other diagrams is:

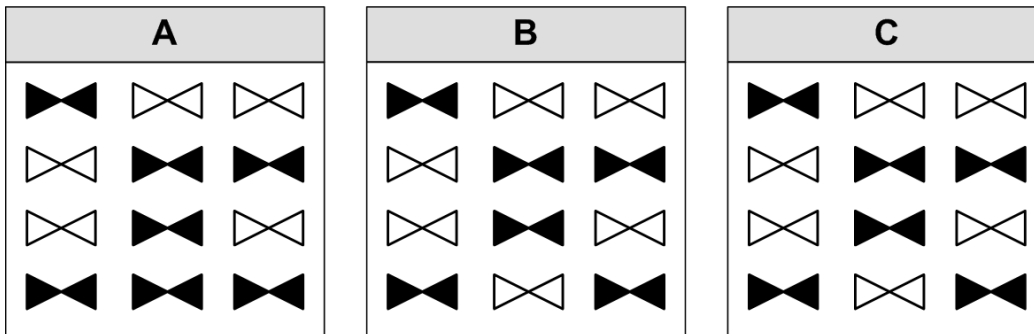

- a. A
- b. B
- c. C
- d. All of the diagrams are the same.

12. The diagram below that is different than the other diagrams is:

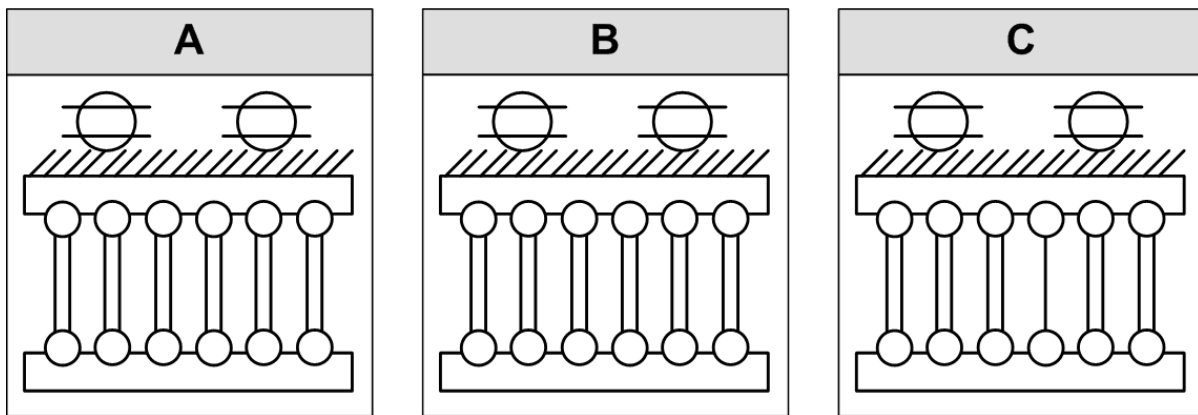

- a. A
- b. B
- c. C
- d. All of the diagrams are the same.

13. The following wiring connections are required:

- Block Point A1 must connect to L3
- Block Point A2 must connect to N3
- Block Point A3 must connect M1

The diagram below that contains the required connections is:

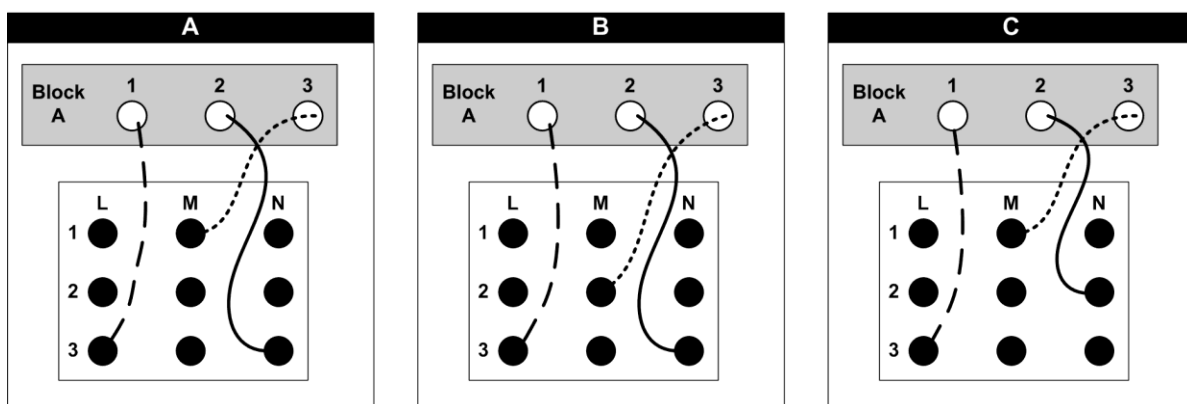

- a. A
- b. B
- c. C
- d. None of the above.

14. The following wiring connections are required:

- Block Point A4 must connect to Q2
- Block Point A5 must connect to O3
- Block Point A6 must connect to P2

The diagram below that contains the required connections is:

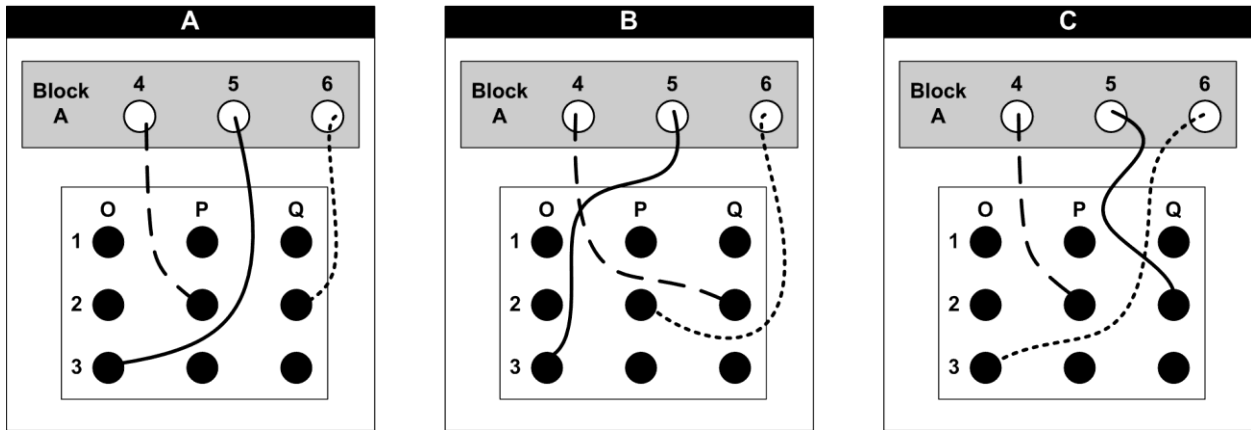

- a. A
- b. B
- c. C
- d. None of the above.

15. The following wiring connections are required:

- Block Point A7 must connect to S3
- Block Point A8 must connect to R2
- Block Point A9 must connect to S2

The diagram below that contains the required connections is:

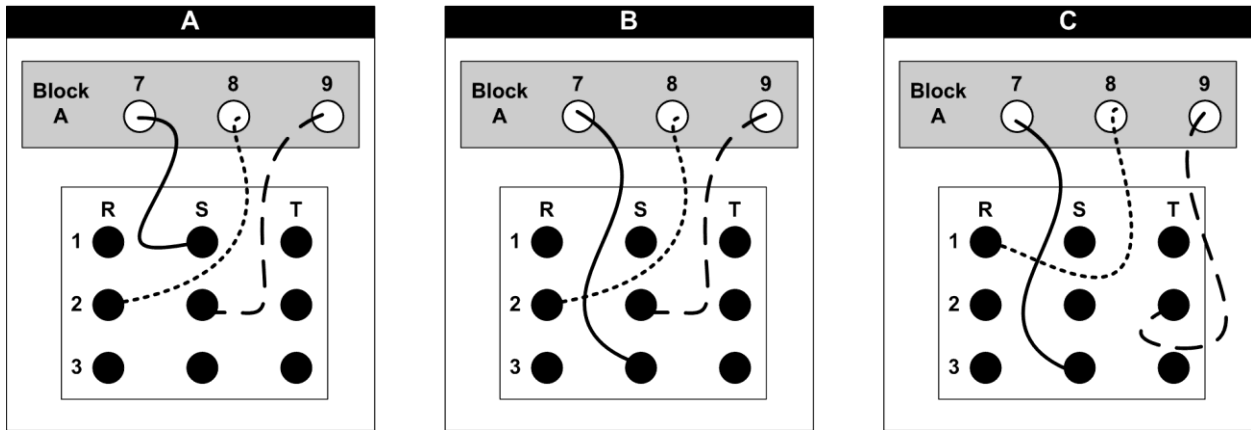

- a. A
- b. B
- c. C
- d. None of the above.

16. The valve in the diagram below that is located south and east of the start point of Main 2145 is:

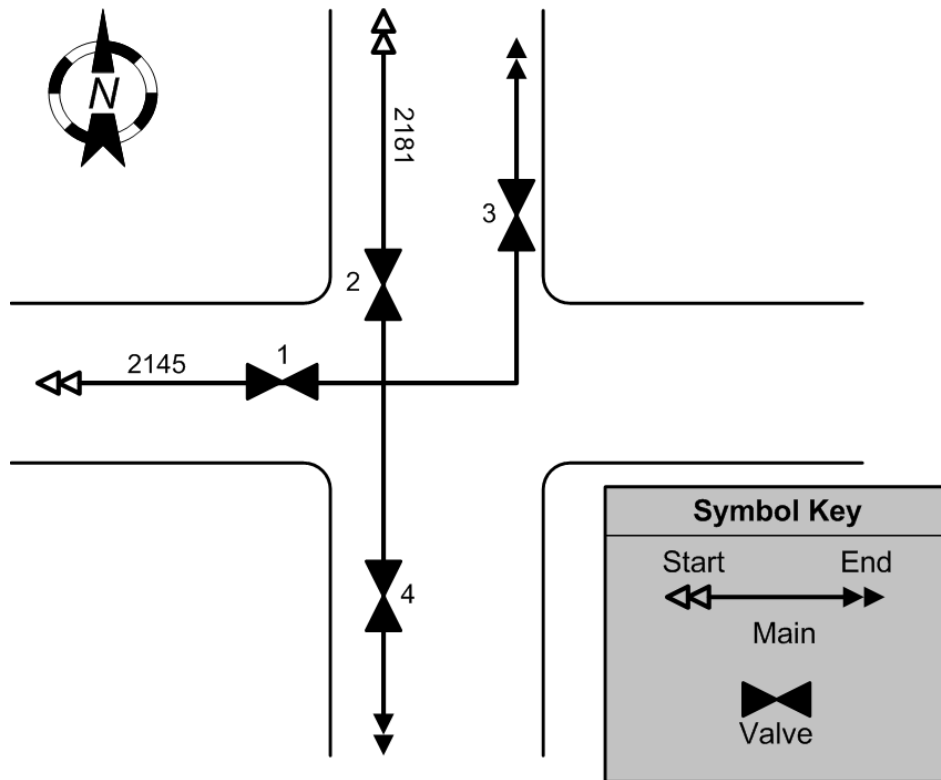

- a. Valve 1
- b. Valve 2
- c. Valve 3
- d. Valve 4

Comprehension

Answer question 17 by reference to the information in the Procedure 1 information below.

Procedure 1

The following requirements must be completed prior to PSE&G installing a gas meter at a residence with a new gas service:

- ***There must be an active electric service to the building where the gas meter is to be set. Refer to the meter set guidelines before you locate your meter and house riser.***
- ***At least one major appliance must be installed and ready to be turned on and adjusted at the time of meter installation.***
- ***The municipal "piping pressure test" yellow sticker must be affixed to the house piping or the premises.***

Source: Based on PSEG materials.

17. A customer has installed gas piping in a garage that is not attached to the house. The garage is not connected to an active electrical service. Because the garage is unheated the customer has installed a small gas heating appliance in the garage. The appliance itself is ready in all respects for a gas turn on. A piping pressure test has been completed by the municipal inspector and a yellow sticker has been attached to the piping.

Based on the information in Procedure 1, PSE&G will not install a gas meter because the:

- a. garage is not connected to the house.
- b. garage is not connected to active electrical service.
- c. piping system has not been pressure tested.
- d. municipal blue tag is missing.

Answer questions 18 and 19 by reference to the information in the Procedure 2 information below.

Procedure 2

- ***Meter and meter set piping installed within a building must be located in a ventilated space readily accessible for examination, reading, replacement, or necessary maintenance.***
- ***Meters installed within a building must be installed not less than 3 ft. from any source of ignition, or any source of heat, which may damage the meter.***
- ***Residential meters shall be located as close as possible to the service entrance, preferably on the front wall, and in a lighted area.***

Source: Based on PSEG materials.

18. A meter and meter set piping has been installed inside an unventilated closet within a customer's basement. According to Procedure 2, this action is:
- a. consistent with Procedure 2.
 - b. inconsistent with Procedure 2.
 - c. There is not enough information to make a determination.
19. A gas meter has been installed in a customer's finished basement. The nearest source of heat or ignition is 4-1/2 feet from the gas meter. According to Procedure 2, this action is:
- a. consistent with Procedure 2.
 - b. inconsistent with Procedure 2.
 - c. There is not enough information to make a determination.

Answer question 20 by reference to the information in the Procedure 3 information below.

Procedure 3

Gas Meter Set Units shall be located at least 3 ft. from electrical meters and other sources of ignition. Gas Meter Set Units shall not be installed closer than 2 ft. from the front of an electric panel on an adjacent wall, opposite or another wall.

Source: Based on PSEG materials.

20. According to Procedure 3, the gas meter set unit installation appearing in the diagram below is:

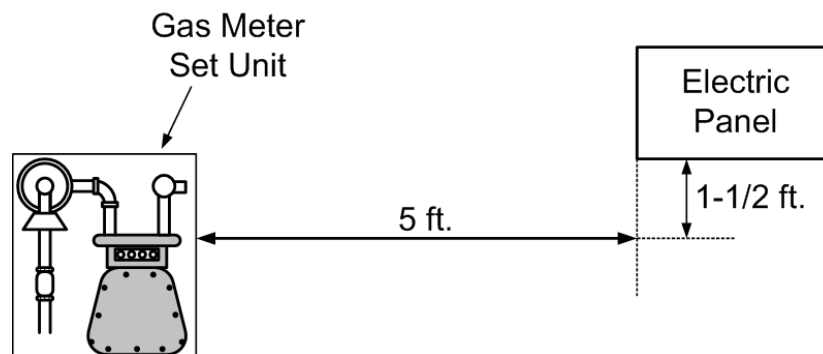

- a. permissible.
- b. prohibited.
- c. There is not enough information to make a determination.

Answer question 21 by reference to the information in Table 1 below:

Table 1 Repair Action Classification		
Class A	Class B	Class C
Class A repairs shall be made safe immediately and repaired as soon as possible.	Class B repairs shall be kept under surveillance as required by their severity and repaired or rechecked within 6 months.	Class C repairs shall be repaired or rechecked at intervals no greater than 15 months.

21. The company assigns a service mechanic to perform a routine check of a repair that was last checked eight months ago. It is likely that this repair had previously been classified as a:
- a. Class A Repair.
 - b. Class B Repair.
 - c. Class C Repair.
 - d. Any of the above.

Answer questions 22 and 23 by reference ONLY to the information in Table 2 below:

Table 2				
Typical Natural Gas Makeup				
Element	Content (%)		Element	Content (%)
Methane	95		Nitrogen	0.3
Ethane	1.7		Butane	0.2
CO	0.9		Pentane	0.1
Propane	0.3			

Source: Based on PSEG materials.

22. Natural gas is composed of methane, ethane, CO, propane, nitrogen, butane, pentane and mercaptan. This statement is:
- a. True.
 - b. Untrue.
 - c. Inconclusive.
23. Natural gas is primarily composed of methane and ethane. This statement is:
- a. True.
 - b. Untrue.
 - c. Inconclusive.

Refer to the graph below to answer items 24 – 25.

Table 3: Capacity of Material (Cubic Feet Per Hour)					
Material Size	Material Diameter (in inches)	Capacities (Cubic Feet Per Hour)			
		Length of Material (in feet)			
		20 feet	30 feet	40 feet	50 feet
A	3.215 inches	4030	3630	3470	3260
B	5.321 inches	7800	6640	6270	5830
C	7.210 inches	8120	7920	7530	6890

24. The capacity of 20 feet of material of Size A is:

- a. 7,800 cubic feet per hour.
- b. 3,630 cubic feet per hour.
- c. 8,120 cubic feet per hour.
- d. 4,030 cubic feet per hour.

25. As the diameters of the material increase, the capacities:

- a. increase.
- b. decrease.
- c. remain the same.
- d. No conclusion can be drawn.

Refer to the Graph below to answer items 26 – 27.

Graph: Relationship of Measurement 1 to Measurement 2

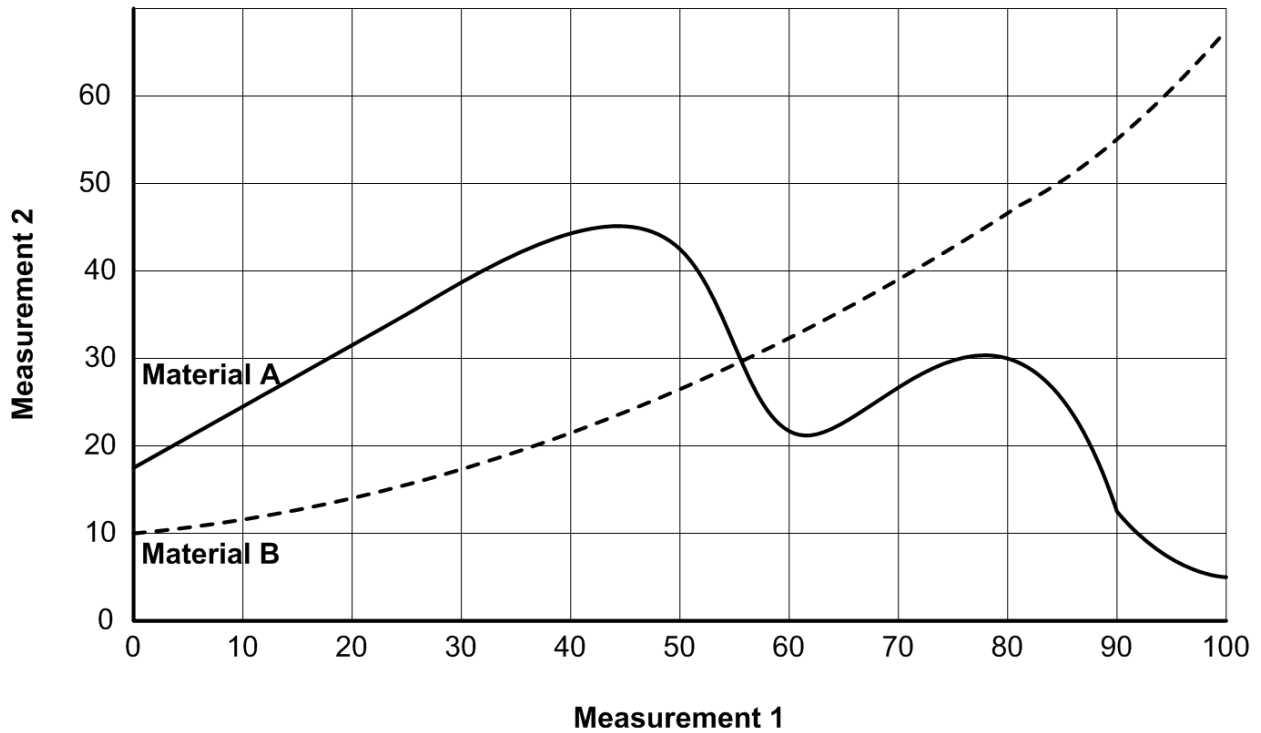

26. For Material A, when Measurement 1 equals 55, Measurement 2 equals approximately:
- a. 25
 - b. 30
 - c. 35
 - d. 40
27. For Material B, as Measurement 1 increases, Measurement 2:
- a. always increases.
 - b. always decreases.
 - c. always remains constant.
 - d. increases and decreases periodically.

Problem Solving

Refer to the map below to answer items 28 – 29.

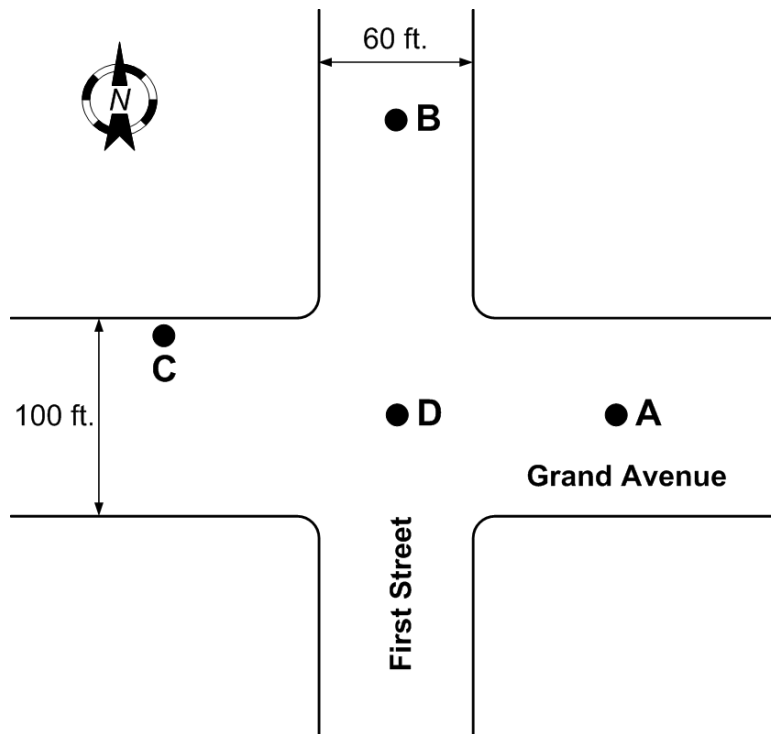

28. The point that is located at the center of First Street and the center of Grand Avenue is:
- a. A
 - b. B
 - c. C
 - d. D
29. The point that is located approximately 150 ft. north of the center Grand Avenue and approximately 100 ft. west of Point A is:
- a. B
 - b. C
 - c. D
 - d. None of the above.

Refer to the Water Flow Diagram below to answer items 30 – 31. You may assume that all correct pressures and venting are present for proper water flow. The valves alone control the flow of the water.

Water Flow Diagram

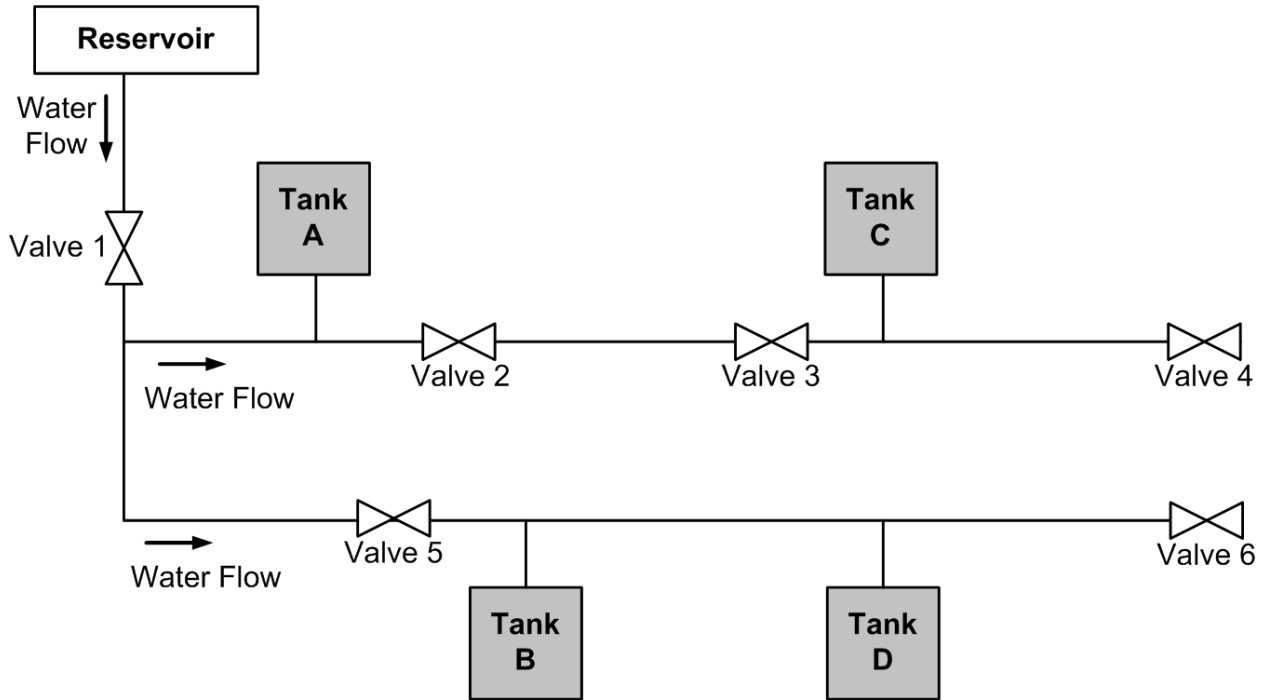

30. For Tank C to fill with water from the reservoir, the following valves must be open: *(Assume all valves are currently closed and must be open for water to flow.)*
- 1, 2, and 3.
 - 1, 2, 3, and 4.
 - 2, 3 and 4.
 - 1, 2, 3, 4, 5, and 6.
31. To fill all four tanks with water from the reservoir, the total number of valves that must be opened is: *(Assume all valves are currently closed and must be open for water to flow.)*
- 3
 - 6
 - 2
 - 4

Refer to the Gas Flow Diagram below to answer item 32.

Gas Flow Diagram

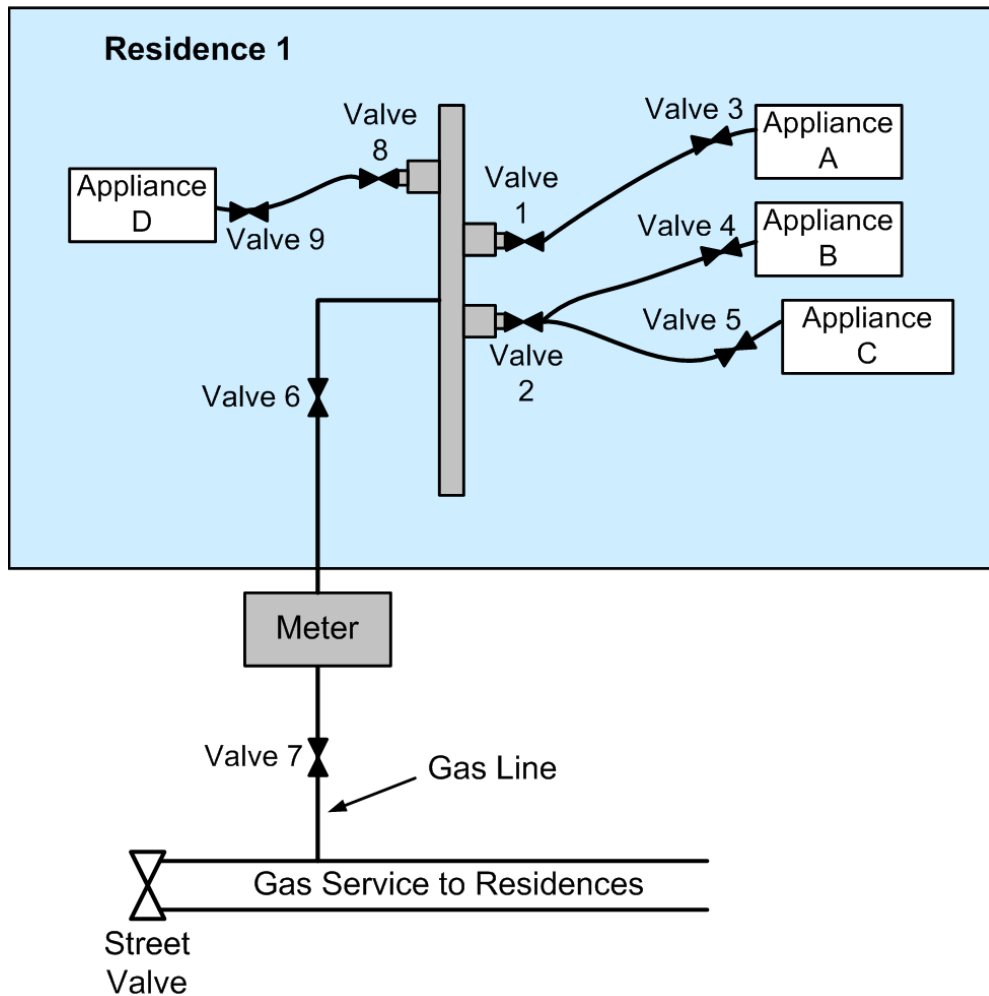

32. Based on the gas flow diagram above, the valve(s) that must be closed to stop gas flow **ONLY** to Appliance B of Residence 1 is (are): (Assume all valves are currently open and that gas is flowing from the street valve into the gas service, through the meter and into the residences through open valves.)
- a. 4
 - b. 7
 - c. 2
 - d. 6

Refer to the diagram below to answer item 33.

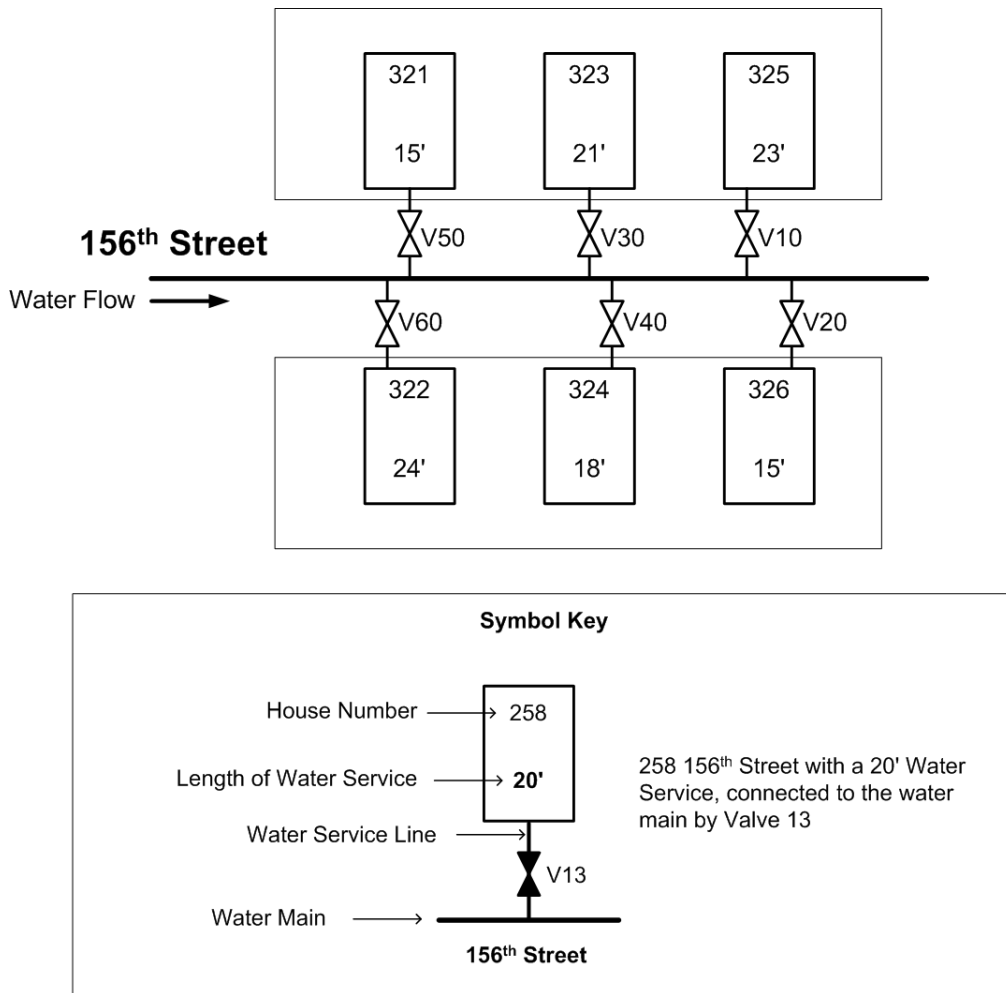

33. The length of water service at 323 156th Street is:

- a. 30'
- b. 23'
- c. 21'
- d. 15'

For items 34 – 36, determine the next item in the pattern.

34. Select the next letter in the following series:

AAAAABBBBCCDD

- a. A
- b. E
- c. C
- d. D

35. Select the next number in the following series:

5 10 20 40 80 160

- a. 240
- b. 280
- c. 320
- d. 400

36. Select the next letter/number in the following series:

A12 B10 C8 D6 E4 F

- a. 1
- b. 12
- c. 3
- d. 2

For items 37 – 38, determine the logical conclusion to the facts provided.

37. If Box 3 is narrower than Box 2 and Box 2 is narrower than Box 1, then:
- a. Box 1 is equal in width to Box 3.
 - b. Box 1 is narrower than Box 3.
 - c. Box 1 is wider than Box 3.
 - d. Box 3 is wider than Box 1.
38. A storekeeper purchased more nuts than bolts. The storekeeper purchased fewer flat washers than lock washers, but more lock washers than nuts. Therefore, it is true that the storekeeper purchased:
- a. the same quantity of flat washers and nuts.
 - b. more nuts than flat washers.
 - c. fewer bolts than flat washers.
 - d. more lock washers than bolts.

For items 39 – 40, apply mechanical principles to solve the problem.

39. Box X and Box Y have been placed on the see-saw below. If Box X weighs more than Box Y, then Box X will:

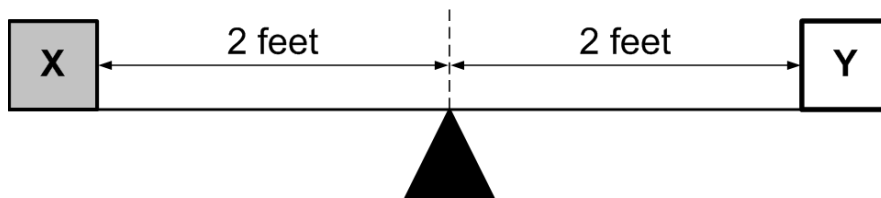

- a. move upward.
- b. move downward.
- c. remain in balance with Box Y.

40. The wheels in the diagram below are perfectly connected. The rotational direction of one wheel impacts the rotational direction of the other wheels. If Wheel A is turning in the direction indicated, then the wheel(s) also turning in the same direction is(are):

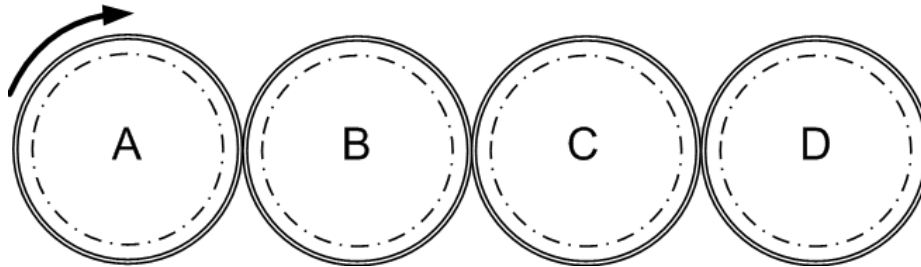

- a. Wheel C only.
- b. Wheels B and D.
- c. Wheels C and D.
- d. Wheels B, C and D.

For items 41 – 42, determine the relationship between the items presented.

41. Saw is to Cut as Hammer is to:

- a. Gouge.
- b. Drive.
- c. Grind.
- d. Ream.

42. Up is to _____ as North is to South.

- a. Away
- b. East
- c. Down
- d. West

Numerical Computation

43. 14 is _____% of 280.
- a. 5%
 - b. 7%
 - c. 14%
 - d. 20%
 - e. None of the above.
44. $109,574 - 104,157 =$
- a. 5,317
 - b. 5,407
 - c. 5,417
 - d. 5,397
 - e. None of the above.
45. $8\text{-}3/4 + 7/8 =$
- a. $8\text{-}13/16$
 - b. $9\text{-}1/8$
 - c. $9\text{-}3/8$
 - d. $9\text{-}5/8$
 - e. None of the above.
46. .125 is equivalent to a fraction of:
- a. $1/12$
 - b. $1/8$
 - c. $1/16$
 - d. $1/32$
 - e. None of the above.

47. The sum of the following fractions is:

$$3\frac{3}{8} + 12\frac{5}{16} + 4\frac{3}{4} + 10 =$$

- a. $29\frac{9}{16}$
- b. $29\frac{7}{8}$
- c. $30\frac{1}{4}$
- d. $30\frac{7}{16}$
- e. None of the above.

48. The reading on the measurement instrument below is:

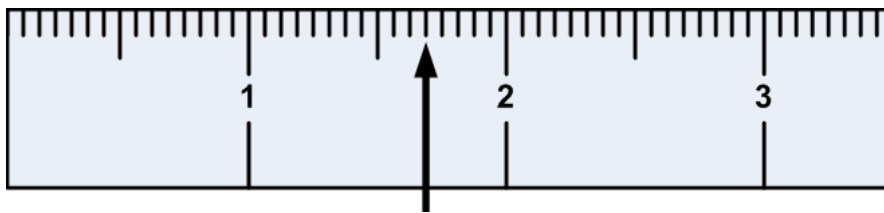

- a. $1\frac{11}{16}$
- b. $1\frac{9}{16}$
- c. $1\frac{3}{4}$
- d. $1\frac{5}{8}$
- e. None of the above.

49. If the scale on a map is $1'' = 50'$, an actual distance of $37.5'$ equals a distance on the map of:

- a. $7.5''$
- b. $\frac{3}{4}''$
- c. $3.75''$
- d. $1.5''$
- e. None of the above.

50. A certain regulator station contains four valves. It takes seven complete turns of the valve to fully close each valve. There are 12 identical regulator stations in District 70. The total number of turns required to close every valve in District 70, if they were all open is:

- a. 28
- b. 84
- c. 336
- d. 488
- e. None of the above.

51. The volume (in cubic feet) of the earth removed from a rectangular hole in the ground can be found by the following formula:

$$\text{Volume} = \text{Length} \times \text{Width} \times \text{Depth}$$

If the hole is 10 feet long by 5.5 feet wide by 4 feet deep, the volume of the earth removed is:

- a. 55 cubic feet
- b. 220 cubic feet
- c. 22 cubic feet
- d. 40 cubic feet
- e. None of the above.

52. Using the formula in Question 51 above, the volume of earth taken from an excavation is 300 cubic feet, the length of the excavation is 6 feet and the width is 5 feet. The depth of the excavation is:

- a. 3 feet
- b. 6 feet
- c. 10 feet
- d. 15 feet
- e. None of the above.

53. The ratio of Liquid X to Liquid Y in a mixture is 3 to 7. If the amount of Liquid Y in a mixture is 161, then the amount of Liquid X in the mixture is equal to:
- a. 23
 - b. 69
 - c. 16.1
 - d. 138
 - e. None of the above.
54. A pump pushes out water at the rate of 30 gallons per minute. At this rate, how long would it take to pump out an excavation containing 102,600 gallons of water?
- a. 48 hours
 - b. 57 hours
 - c. 84 hours
 - d. 152 hours
 - e. None of the above.
55. A gauge shows that at the start of the day, the pressure was - 4.5 psi and at the end of the day the gauges recorded a pressure of + 5.5 psi. The total change in pressure over the course of the day was:
- a. - 1.5 psi
 - b. - 10 psi
 - c. + 1.5 psi
 - d. + 10 psi
 - e. None of the above.
56. The manufacturer recommends that the oil in an air compressor should be changed after the first 950 hours of operation. However, the engineers recommend changing the oil when the operating hours reach 60 percent of the manufacturer's recommendation. According to the engineers, the oil should be changed at:
- a. 760 hours
 - b. 665 hours
 - c. 570 hours
 - d. 1,583.3 hours
 - e. None of the above.

Written Expression

For items 57 – 60, select the word that means nearly the same as the underlined word.

57. A low gas pressure situation must be remedied as soon as possible.

- a. discovered
- b. analyzed
- c. explored
- d. corrected

58. Make certain that any debris is properly taken care of.

- a. waste
- b. raw material
- c. product
- d. recyclable

59. Do not excavate until you have first called for a mark out.

- a. pile
- b. dig
- c. backfill
- d. bury

60. If the reading is too high, you must ventilate the space.

- a. air out
- b. compress
- c. spray
- d. clean

For items 61 – 62, select the word that is spelled correctly.

61. The word that is spelled correctly is:

- a. spesification
- b. procedere
- c. solution
- d. preparashun

62. The word that is spelled correctly is:

- a. compression
- b. mecanical
- c. thickeness
- d. connecsions

For item 63, select the line that contains a grammatical/punctuation error.

63. In the sentence below, select the line (a, b or c) that contains a grammatical/punctuation error:

- a. The specialist tested
- b. and inspect
- c. all of the furnace control circuits.
- d. There is no grammatical error in the sentence above.

For item 64, select the word that best completes the sentence.

64. The gas analysis _____ performed according to the correct standards.

- a. was
- b. were
- c. won't

For item 65, select the sequence of numbers that represents the best unscrambled sentence.

65.

<u>manhole</u>	<u>please</u>	<u>the</u>	<u>ventilate</u>	<u>performing</u>	<u>the</u>	<u>task</u>	<u>before</u>
1	2	3	4	5	6	7	8

- a. 2-5-6-7-8-4-3-1
- b. 5-6-7-8-4-3-1-2
- c. 2-4-3-7-8-5-6-1
- d. 2-4-3-1-8-5-6-7

For item 66, select the correct sequence of sentences.

66. A correct, logical and ordered sequence of events for the information in the sentences below is:

- 1. The water leak was found and repaired.
 - 2. The police reported a water leak to the water emergency desk.
 - 3. The leak repair crew completed a water leak repair report.
 - 4. The leak repair crew arrived at the location.
 - 5. The water emergency desk dispatched a leak repair crew.
-
- a. 2-5-4-1-3
 - b. 4-1-3-2-5
 - c. 5-2-1-4-3
 - d. 2-4-1-3-5

**Practice Test for Placement Exercise
Answer Key**

Question	Answer		Question	Answer		Question	Answer
1	C		26	B		51	B
2	D		27	A		52	C
3	D		28	D		53	B
4	C		29	A		54	B
5	B		30	A		55	D
6	A		31	D		56	C
7	B		32	A		57	D
8	D		33	C		58	A
9	C		34	B		59	B
10	C		35	C		60	A
11	A		36	D		61	C
12	C		37	C		62	A
13	A		38	D		63	B
14	B		39	B		64	A
15	B		40	A		65	D
16	D		41	B		66	A
17	B		42	C			
18	B		43	A			
19	A		44	C			
20	A		45	D			
21	C		46	B			
22	B		47	D			
23	A		48	A			
24	D		49	B			
25	A		50	C			